

article#	845-6v-P953
article description	CEE socket 16/5 6h IP44 w. concrete box
description long	complete set consisting of: 1x concrete membrane box M1 CEE, installation depth 85mm (type PRIMO #P953) 2x wings for attachment to the steel reinforcement (type PRIMO #P761) 1x CEE-flanged design socket 16A 5p IP44 white (PCE #845-6v) incl. mounting screws 1x cover frame 1-way white with gasket (PCE #9021) 1x mounting instructions
GTIN (EAN)	9003399599408
country of origin	AT
customs number	85366990
net weight	0.350 kg
packaging quantity	1
minimum order quantity	1

ETIM 9.0	EC001321
Model	Flush-mounted
IEC-amperage	16 A
Number of poles	5
Voltage according to EN 60309-2	400 V (50+60 Hz) red
Clock hour position	6 h
Identification colour	Red
Degree of protection (IP)	IP44
Connection system	Screwed terminal
Material	Plastic
Contact material	CuZn
Surface treatment contacts	Nickel-plated

wire flexible	1-2x2,5 mm ²
wire solid	1-2x4 mm ²
contact screws	100 Ncm
dismantling length	50 mm
stripping length	10-12 mm
ambient temperature	-25 – 40 °C
temperature resistance	-25 – 80 °C

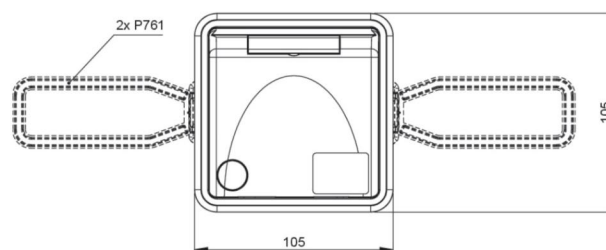
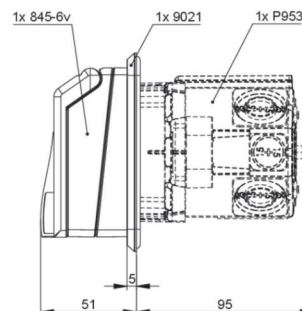

<https://www.pcelectric.at/shop/en/?func=detail&artnr=845-6v-P953>